

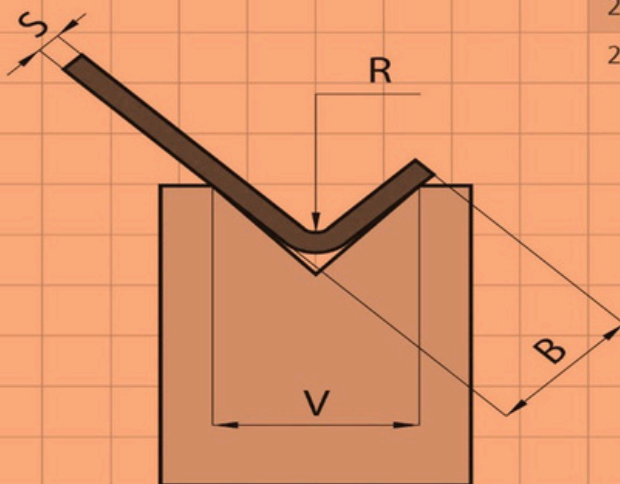

SHEET METAL BENDING TABLE

V	R	B	S	0.5	0.8	1	1.2	1.5	1.8	2	2.5	3	4	5	6	8	10	12	15	20	25	
4	0.7	2.6		4	10.5																	
6	1	4		3.5	6	10	13															
8	1.5	5.2		2	5.5	8	11.5	18														
10	1.7	6.5			4.1	6.5	9.5	14.5	21	26												
12	2	7.8				5.5	8	12	17.5	21.5	33.5											
16	2.7	10.4					6	9	13	16	25	36										
20	3.4	13						7.5	10.5	13	20	29	52									
25	4.2	16							8.5	10.5	16	23	41	64								
30	5	20									14	19	34	54	77							
35	6	23										17	30	46	66							
40	7	26										15	26	40	58	103						
45	7.5	29											23	36	52	91						
50	8.5	32											21	32	46	82	128					
55	9	36												30	42	75	117					
60	10	39												27	39	69	107					
65	10.8	42												25	36	63	99	142				
70	11.7	45													33	59	92	132				
75	12.5	49													31	55	86	123				
80	13.5	52													29	52	80	116	180			
85	14	55														49	76	109	170			
90	15	58														46	71	103	160			
100	17	65														41	64	93	144	256		
110	18.5	71															59	84	131	233		
120	20	78															54	77	120	213	333	
140	24	91																66	103	183	286	
170	29	110																	55	85	151	235



V = (mm)
R = (mm)
B = (mm)
S = (mm)
F = (KN/m)

Forza di piegatura al metro per materiale con resistenza di 400 N/mm². Per resistenza di 800 N/mm²(Inox) moltiplicare la forza per 2.

Bending force per meter for material tensile strength of 400 N/mm². For tensile strength of 800 N/mm²(Inox) multiply the bending force by 2.

Biegekraft pro Meter für eine Materialfestigkeit von 400 N/mm². Für eine Festigkeit von 800 N/mm²(Inox), bitte die Biegekraft verdoppeln.

Force de pliage par mètre pour une matière ayant une résistance de 400 N/mm². Pour une résistance de 800 N/mm²(Inox) multiplier la force par 2.

Machinery complying with regulations



Pensare verde: per cortesia considerate l'ambiente prima di stampare.
Think green: please consider the environment before printing.

konzu s.r.l.s.
Tel. 392-7573175
www.konzusrls.com
E-mail: konzusrl@gmail.com

This e-mail and its attachments may contain information that is confidential only to the RECIPIENT specified in the address. The information transmitted by this e-mail and its attachments are intended solely for the addressee and must be considered confidential and may not be disclosed or used without express permission. Should this e-mail and its attachments be received by mistake by a person other than the addressee, please destroy everything received and inform the sender by the same means. Any unauthorised use, disclosure or copying of this communication is strictly prohibited and will result in violation of the provisions of the Personal Data Protection Act EUROPEAN REGULATION 2016/679.